

M. RUMELY.
FRICTION-CLUTCH.

No. 189,062.

Patented April 3, 1877.

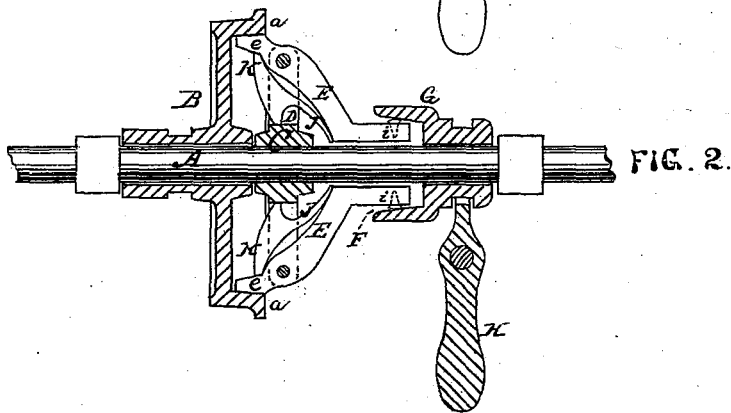
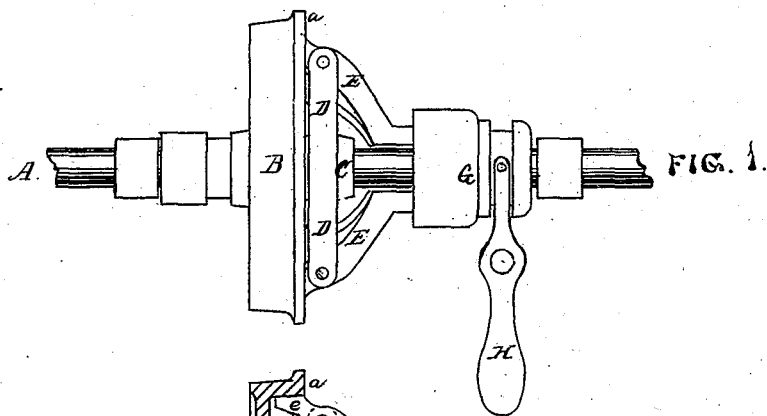

Witnesses
Forde R. Smith
James S. Murray

Meinrad Rumely Inventor
Munday G. Everts

Attorneys

UNITED STATES PATENT OFFICE.

MEINRAD RUMELY, OF LA PORTE, INDIANA, ASSIGNOR OF ONE-HALF HIS
RIGHT TO JOHN RUMELY, OF SAME PLACE.

IMPROVEMENT IN FRICTION-CLUTCHES.

Specification forming part of Letters Patent No. **189,062**, dated April 3, 1877; application filed
December 6, 1876.

To all whom it may concern:

Be it known that I, MEINRAD RUMELY, of La Porte, in the county of La Porte and State of Indiana, have invented certain Improvements in Friction-Clutches, of which the following is a specification:

In the accompanying drawing, which forms a part of this specification, Figure 1 is an elevation, and Fig. 2 a section, of my improved clutch.

Like letters of reference indicate the same parts in both figures.

In the said drawing, A is the shaft. B is the loose pulley to which the clutch is to be applied. This pulley turns loose upon the shaft, except when engaged by the clutch, which bears against the inside of the rim *a*. C is a hub, rigidly affixed to the shaft A, adjacent to the pulley B. This hub is provided with one or more pairs of radiating arms, D, in the outer ends of which are pivoted the friction-levers E E, each provided with a friction-shoe, *e*, which sets out against the inner surface of the rim *a* when the levers are brought into action. These levers E E are bent, so that their long arms, at their outer extremity or ends farthest from the pulley, lie about parallel to the shaft. These ends of the long arms of said levers enter the cone-shaped hollow F of the sliding head G, to which the hand-lever H is connected.

When this sliding head is moved toward the pulley, the cone, acting upon the ends of the levers, forces them toward the shaft, which motion throws the shoes *e* out against the inside of the rim *a* of the pulley, thus locking the pulley to the shaft.

For the purpose of adjustment, the ends of the levers E E within the cone are fitted with

set-screws *i i*, by which the motion may be regulated, as these screws form the bearing-points. Springs J J are provided to keep the levers away from engagement when the head G is moved back, and stops K K serve to prevent too great a motion of the levers by the springs.

The friction-surfaces of the pulley should be truly turned, in order to present a smooth, just surface, and the bearing-surface of the shoes prepared in like manner, which may be done by locking the levers E in a lathe, in a very perfect manner.

The points of advantage in this clutch are, the simplicity of its construction, its strength and durability, its capability of perfect adjustment, and the great force and certainty of its operation.

Of course, the number of pairs of levers E E, arranged oppositely to each other, as in the drawing, may be increased from a single pair, as shown, to several, if desired; but a single pair will most generally be found sufficient under ordinary circumstances.

Having thus described my invention, that which I claim as new, and desire to secure by Letters Patent, is—

The combination of the loose pulley B, provided with a rim, *a*, the bent levers E E, provided at one end with shoes *e e*, and at the other end with set-screws *i i*, the hub *c*, provided with arms D and springs J, and the hollow-cone sliding head G, into the interior of which enter the ends of the levers E, substantially as set forth.

MEINRAD RUMELY.

Witnesses:

H. HANSHEER,
T. J. CONING.